

Assembly instructions

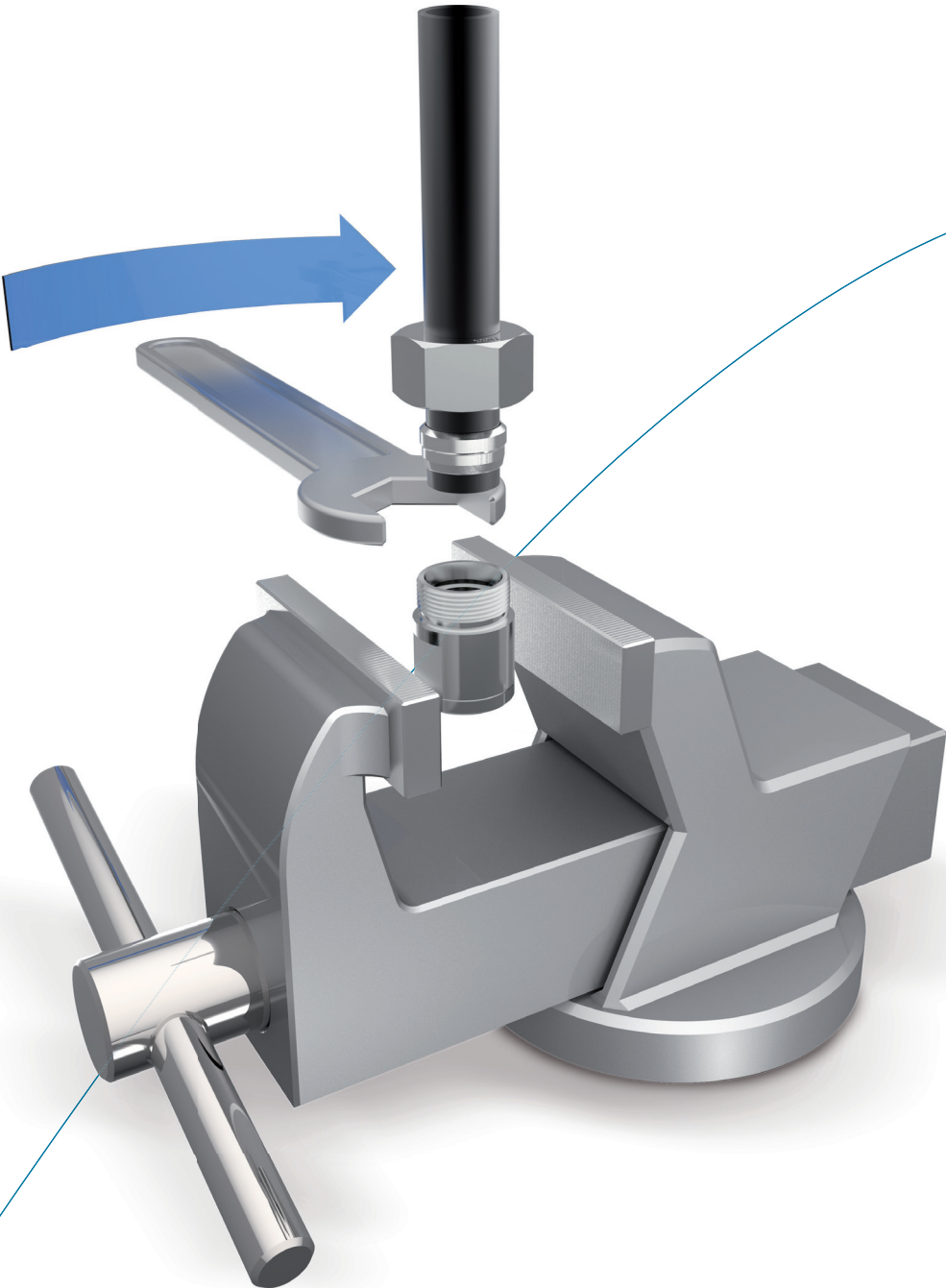

## Important notes on VOSS assembly instructions

In order to ensure maximum performance and functional reliability of VOSS products, the respective assembly instructions, operating conditions and tube recommendations have to be adhered to.

We recommend that you use VOSS pre-assembly devices at all times. It is absolutely essential to follow the operating instructions for the respective pre-assembly device used.

Do not start with assembly until you are absolutely sure that you have understood the operating and assembly instructions for each VOSS pre-assembly device or machine, tool and product. Incorrect handling leads to risks regarding safety and leak-tightness and can result in failure of the entire connection.

It is impossible for the manufacturer to monitor whether the user is adhering to the operating and assembly instructions for individual pre-assembly devices or machines, tools and products, as well as what conditions prevail and what methods are used for installation, operation, application and maintenance of the individual products. Improper workmanship can lead to material damage, which in turn may pose a danger to life and limb. This means that VOSS Fluid GmbH can accept no responsibility or liability for loss, damage or costs incurred due to faulty installation, improper operation or incorrect application and maintenance or from any related issue. Failure to heed this warning will lead to loss of guarantee.

VOSS Fluid GmbH reserves the right to make changes or additions to the information provided without prior notification. Customers can obtain the latest version of the operating and assembly instructions upon request, or from our download area at: [www.voss.net](http://www.voss.net)

## General notes on VOSS assembly instructions

Make sure that all components, including the tubes, are clean before assembly is started and that they remain clean during the entire assembly process. Soiled components may lead to failure of the system.

Before starting assembly, make sure that you have carried out all preparatory work in accordance with the respective instructions.

### Specifications concerning permissible steel tubes:

seamless, cold-drawn and normalized precision steel tubes as specified in DIN EN 10305-4, material E235+N, mat. no. 1.0308+N or E355, mat. no. 1.0580. The tubes must be ordered by specifying the outer diameter and the inner diameter.

### Specifications concerning permissible stainless steel tubes:

seamless, cold-drawn and solution-annealed, scale-free stainless steel tubes in CFA or CFD delivery condition of dimensions and tolerances according to DIN EN 10305-1 and all other delivery conditions as specified in DIN EN 10216-5, material X6CrNiMoTi17-12-2, mat. no. 1.4571. The tubes must be ordered by specifying the outer diameter and the inner diameter.

The tubes should be prepared with the same thoroughness as pre-assembly and final assembly of the connection. Especially when using long tubes, check the end sections for damage or distortion.

We recommend that pre-assembled tubes which are not to be finally assembled yet should be fitted with protective caps.

Marking a stroke on the union nut and the tube makes it easier to achieve the correct number of turns when tightening the coupling.

Before starting to assemble VOSS components with elastomer seals, always check that:

- the nut and the seal surfaces are clean and undamaged and/or
- the elastomer sealing is clean and undamaged

## Determining the tightening torque for screw couplings

The tightening torques specified in the catalogue apply under the following conditions:

- steel fittings with VOSS coat surface coating
- the specified nominal pressure ranges assume that the mating material has a tensile strength of  $\geq 600 \text{ N/mm}^2$
- our recommendations on lubrication of the threaded studs are observed

If other values for strength, modulus of elasticity and friction-surface combinations are used, the user has to adapt the tightening torque empirically.

The recommended tightening torques have to be adhered to if the pressure range is to be fully utilized and the appropriate safety level is to be maintained.

The recommended tightening torques for the threads are given in the tables for the respective type of thread.

## Explanation of symbols and other notes



Visual inspection



Turn until hand-tight or carry out another manual activity



Use the tool to tighten the coupling according to the instructions



Oil and lubricate at the point marked with an arrow

All dimensions in millimetres [mm]

# Assembly instructions for adjustable couplings as specified in ISO 6149 / 11926-1

## 1

### Notes

Before starting the assembly work, read and observe the general notes in the up-to-date VOSS catalogue and check that your assembly instructions are up to date.

These assembly instructions apply to adjustable couplings with lock nuts to be screwed into threaded holes as specified in:

- ISO 6149-1 metric fine thread and
- ISO 11926-1 UN/UNF-thread

#### Attention!

Before installing the coupling, check the thread and the soft seal.

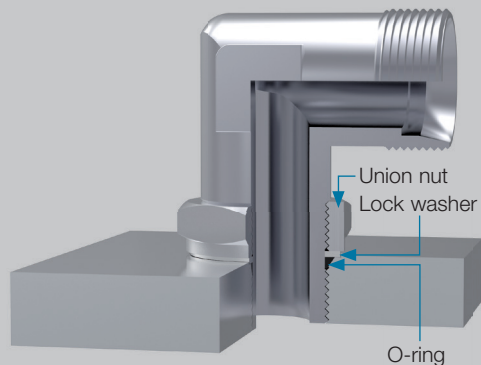

## 2

### Assembly procedure

- Back off the lock nut as shown.
- Push the O-ring and the lock washer up to the top end of the relieved section.
- Lubricate the O-ring and the threads lightly (e.g. using mineral-oil based hydraulic fluid HLP32).
- Screw the fitting in manually until the lock washer rests on the mating surface.
- Turn the screw-in coupling back until it points in the desired direction (but not by more than one turn).
- Hold the coupling with a spanner and tighten up the lock nut.

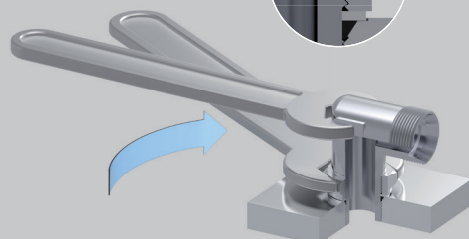
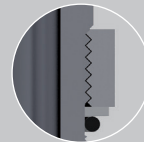

## ISO 6149 / 11926-1

### 3

#### Tightening torques

| Series | Thread     | Tightening torque<br>Nm -10 % |
|--------|------------|-------------------------------|
| L      | M 10 x 1   | 15                            |
| L      | M 12 x 1.5 | 25                            |
| L      | M 14 x 1.5 | 35                            |
| L      | M 16 x 1.5 | 40                            |
| L      | M 18 x 1.5 | 45                            |
| L      | M 22 x 1.5 | 60                            |
| L      | M 27 x 2   | 100                           |
| L      | M 33 x 2   | 160                           |
| L      | M 42 x 2   | 210                           |
| L      | M 48 x 2   | 260                           |
| S      | M 12 x 1.5 | 35                            |
| S      | M 14 x 1.5 | 45                            |
| S      | M 16 x 1.5 | 55                            |
| S      | M 18 x 1.5 | 70                            |
| S      | M 22 x 1.5 | 100                           |
| S      | M 27 x 2   | 170                           |
| S      | M 33 x 2   | 310                           |
| S      | M 42 x 2   | 330                           |
| S      | M 48 x 2   | 420                           |

| Series | Thread            | Tightening torque<br>Nm -10 % |
|--------|-------------------|-------------------------------|
| L      | 7/16 - 20 UNF-2A  | 18                            |
| L      | 1/2 - 20 UNF-2A   | 28                            |
| L      | 9/16 - 18 UNF-2A  | 30                            |
| L      | 3/4 - 16 UNF-2A   | 50                            |
| L      | 7/8 - 14 UNF-2A   | 60                            |
| L      | 1 1/16 - 12 UN-2A | 95                            |
| L      | 1 3/16 - 12 UN-2A | 120                           |
| L      | 1 5/16 - 12 UN-2A | 150                           |
| L      | 1 5/8 - 12 UN-2A  | 200                           |
| L      | 1 7/8 - 12 UN-2A  | 260                           |
| S      | 7/16 - 20 UNF-2A  | 20                            |
| S      | 1/2 - 20 UNF-2A   | 30                            |
| S      | 9/16 - 18 UNF-2A  | 35                            |
| S      | 3/4 - 16 UNF-2A   | 70                            |
| S      | 7/8 - 14 UNF-2A   | 100                           |
| S      | 1 1/16 - 12 UN-2A | 170                           |
| S      | 1 5/16 - 12 UN-2A | 270                           |
| S      | 1 5/8 - 12 UN-2A  | 285                           |
| S      | 1 7/8 - 12 UN-2A  | 325                           |